

**N. T. Isembergenov, A. N. Alsatova**

Kazakh national research technical university named after K. I. Satpayev, Almaty, Kazakhstan.  
E-mail: 50378@avh.kz

## **ENERGY-EFFICIENT FREQUENCY CONVERTER FOR INDUCTION HEATING**

**Abstract.** This article considers an energy-efficient frequency converter for induction heating, which consists of two power transistors, which increases the coefficient of performance and reduces the cost of the frequency converter. This provides a high frequency of current from several kHz to hundreds of kHz. The operating principle of the frequency converter is described.

**Keywords:** induction heating, frequency converter, transistor, energy efficiency and ECE.

Induction heating is a method of contactless heating of electrically conductive materials (metals) by high-frequency currents of high power with the help of frequency converters, the efficiency of which does not exceed 60-80%.

The purpose of the research is to develop a frequency converter for induction heating with the most efficient use of energy consumed with high efficiency and low cost.

Induction heating is used to heat the technological equipment (oil pipeline, pipeline, tank, etc.), heating the metal, fluids, desiccation of coatings, materials (e.g. wood) [1]. The most important parameter of the induction heating installation is the frequency. For each process, there is an optimal frequency range, which provides the best technological and economic indicators. The frequencies from 50 Hz to 5 MHz are used for induction heating of the metal.

The main device of the induction heater is a frequency converter, which consists of a rectifier and an inverter. Depending on the power and frequency, the inverter is assembled from thyristors or transistors [2, 3].

Currently, frequency converters use power transistors, and inverters perform on four transistors, which, with a high switching frequency of transistors and with large inductive load currents, increases the frequency converter losses. This reduces efficiency and increases the ventilation power, which leads to a significant increase in the mass-size dimensions of the frequency converter and a decrease in power in the inductor.

The frequency converter for induction heating with the smallest number of transistors and high efficiency is developed in the article, when it is connected to three-phase power supplies. Scientific recency is the number of transistors reduction to two, which increases the efficiency, which results in saving energy and reducing the cost of the frequency converter.

Figure 1 shows a scheme of frequency converters for induction heating. Frequency converter for induction heating, contains two three-phase rectifiers, two switches on transistors, a high-frequency transformer with two primary and one secondary winding and inductor (Fig. 1). The input of the frequency converter is supplied with an alternating three-phase voltage, which is converted into two constant-voltage sources by two three-phase rectifiers, one has a direct polarity and the other has a reverse polarity. These two sources of direct voltage are turned on against each other (figure 1).

The three-phase rectifier 1 is connected to the first primary winding  $W_1$  of the high-frequency transformer through the first transistor switch  $T_1$  and the second three-phase rectifier 2 is connected to the second primary winding  $W_2$  of the high-frequency transformer through the second transistor switch  $T_2$ , the

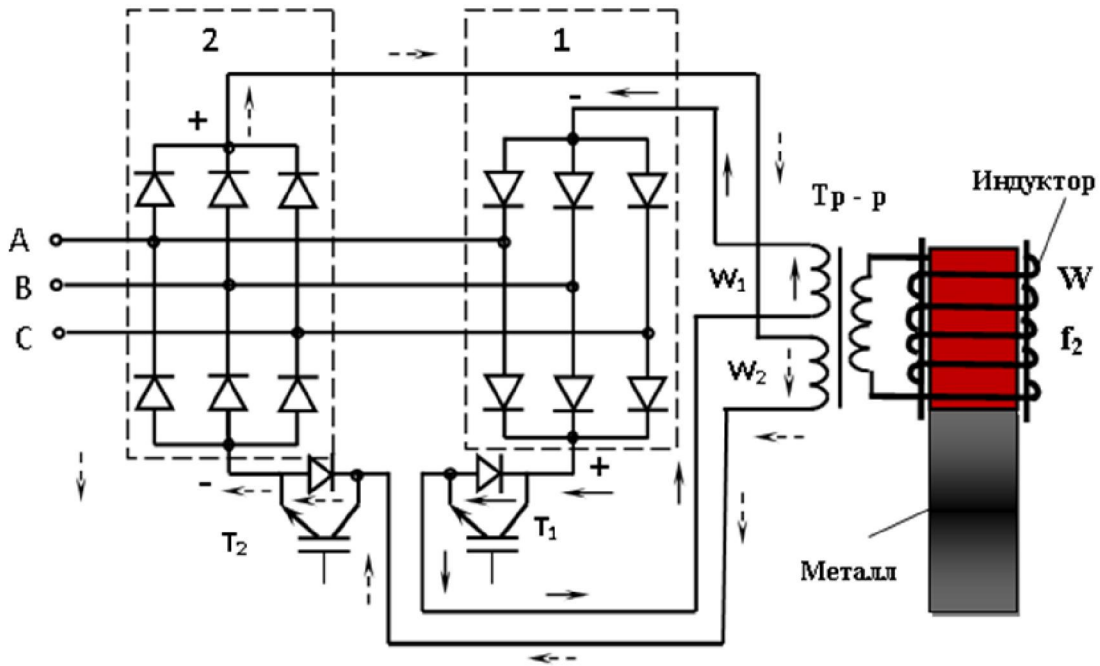

Figure 1 – Diagram of the frequency converter on two JGBT transistors

secondary winding  $W$  of the transformer being connected to an inductor with a number of turns  $W_n$  and, and three-phase rectifiers are powered by a three-phase power supply.

Three-phase rectifiers convert the three-phase voltage into a constant voltage, and the transistor switches  $T_1$  and  $T_2$  convert the DC voltage into an alternating single-phase voltage of the required frequency  $f_n$ . The transformer lowers the alternating voltage of the high frequency to the required value. The secondary winding of the transformer is connected to the inductor.

The frequency converter for induction heating operates in the following way. The three-phase rectifier 1 converts the three-phase voltage into a constant direct polarity voltage (figure 1), and the three-phase rectifier 2 converts the three-phase voltage to a constant reverse polarity voltage, these sources being interdependently connected to one another.

When switching on the transistor switch  $T_1$ , the DC voltage of the three-phase rectifier 1 is connected to the first primary winding  $W_1$  of the high-frequency transformer and the current flows through the winding  $W_1$  to the time  $t_1$  (figure 2). Thus, a positive half-wave of the input voltage of the primary winding  $W_1$  of the high-frequency transformer is formed.

At time  $t_1$ , the transistor switch  $T_1$  is turned off and the transistor switch  $T_2$  is turned on. In this case, the DC voltage of the three-phase rectifier 2 is connected to the second primary winding  $W_2$  of the high-frequency transformer and a reverse polarity current flows through the winding  $W_2$  to the time instant  $t_2$  (figure 2). Thus, a negative half-wave of high-frequency transformer primary  $W_2$  winding input voltage is formed.

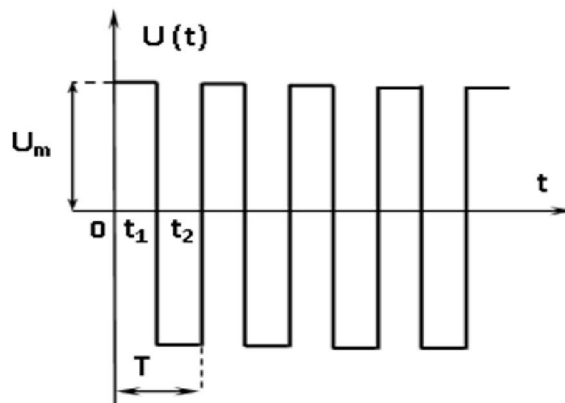

Figure 2 – Graph of the output voltage of the frequency converter

The frequency of the frequency converter voltage for induction heating is determined by the known formula:

$$f_{\text{H}} = \frac{1}{T}, \quad (1)$$

where  $T$  is the voltage period of the frequency converter.

It is known that at a high frequency of voltage, the weight and size dimensions of a high-frequency transformer are reduced, so a frequency converter for induction heating of an oil pipeline will have low weight and dimensions. In addition, the frequency converter is made on two transistors and the electrical losses on the transistors will be less accordingly, which will lead to an increase in the efficiency of the frequency converter, in comparison with the analogue and reducing the cost of the entire frequency converter.

The core of the article is that an improved design of the frequency converter on two JGBT transistors is proposed. At the same time, the design is simpler and more technological for the manufacture and can be made for a specific case. In addition, the developed technology and design methods allow creating an individual induction heater for a particular type of heating process [3].

In figure 1, the frequency converter is connected to the windings of the inductor inside, which is a metal round billet. At the same time, high-frequency current flows through these windings of the inductor, which forms a variable magnetic flux. The variable magnetic flux, crossing the metal walls of the metal, according to the law of electromagnetic induction, induces in it an electromotive force, under the influence of which, an alternating electric current will flow. This current will also heat the metal to the desired temperature.

A prototype of a frequency converter was developed and manufactured. Figure 3 shows a prototype of a frequency converter with a power of 6 kW at frequencies from 2 to 20 kHz. In the frequency converter, the source is a three-phase 380 V power system, of industrial frequency. The frequency converter is implemented on IGBT transistors. The control system is implemented on the logical elements of the mathematical apparatus of the software complex. The rectifier was made on the basis of a bridge with a six-pulse rectification circuit. To match the voltage and galvanic isolation, a double-wound high-frequency power transformer was used.



Figure 3 – Process of induction surface heating of metal with a 120 mm diameter at a frequency of 20 kHz

The results of the experimental study showed that the prototype of the frequency converter works stably, produces the specified technical characteristics. Figure 3 shows the process of induction surface heating of a metal with a 120 mm diameter at a frequency of 20 kHz. This is done to show that the frequency converter only heats the metal surface at a frequency of 20 kHz, with the heating temperature reaching 800 degrees. It is not necessary to heat the oil pipeline to such a temperature, it is sufficient to heat the oil to a temperature of 50 degrees.

It should be especially emphasized that the greatest use of electromagnetic energy will be if the power factor of the inductor is close to one. This can be achieved if a compensating capacitor bank is connected in parallel with the inductor. The compensating battery of capacitors and the inductor form a loading oscillatory circuit in which the reactive energy stored in the magnetic field of the inductor is transferred to the capacitors, passing into the energy of the electric field.

Thus, a frequency converter for induction heating must have an output frequency range within 2-20 kHz. The depth of induction field penetration in this frequency range is 2-5 mm, again depending on the frequency. If further heating is required in the depth of the part, the heating time increases.

#### REFERENCES

- [1] Kuvaldin A.B. Induction-heater of ferromagnetic steel. M.: Energoatomizdat, 1988. 188 p.
- [2] Isembergenov N.T. Frequency converter on two transistors for electrotechnology // XIV International conference Electromechanics, Electrotechnologies, Electrotechnical Materials and Components. Crimea. Alushta, 2012.
- [3] Isembergenov N.T. Frequency converter for induction heating of oil pipeline with three-phase power supply // Patent number 99534. Copyright certificate to the innovative patent. Committee on Intellectual Property Rights of the Ministry of Justice of the Republic of Kazakhstan, Bul. № 18 from 29.09. 2017.

**Н. Т. Исембергенов, А. Н. Альсатова**

Қ. И. Сәтбаев атындағы Қазақ ұлттық техникалық университеті, Алматы, Қазақстан

#### ЭНЕРГИЯНЫҢ ИНДУКЦИЯЛЫҚ ҚЫЗДЫРУҒА АРНАЛҒАН ЭНЕРГИЯСЫНЫҢ ТИІМДІ СИПАТТАМАСЫ

**Аннотация.** Мақалада қуатты транзистордан тұратын индукциялық қыздыру үшін энергияны үнемдейтін жиілікті түрлендіргіш қарастырылады, ол тиімділікті арттырады және жиілікті түрлендіргіштің құнын төмендетеді. Бұл бірнеше кГц - жүздеген кГц-ке дейінгі тоқ жиілігін қамтамасыз етеді. Жиілік түрлендіргішінің жұмыс принципі сипатталған.

**Түйін сөздер:** индукциялық жылу, жиілікті түрлендіргіш, транзистор, энергия тиімділігі және ПӘК.

**Н. Т. Исембергенов, А. Н. Альсатова**

Казахский национальный исследовательский технический университет им. К. И. Сатпаева

#### ЭНЕРГОЭФФЕКТИВНЫЙ ПРЕОБРАЗОВАТЕЛЬ ЧАСТОТЫ ДЛЯ ИНДУКЦИОННОГО НАГРЕВА

**Аннотация.** В статье рассматривается энергоэффективный преобразователь частоты для индукционного нагрева, который состоит из двух силовых транзисторов, что повышает КПД и снижает стоимость преобразователя частоты. При этом обеспечивается высокая частота тока от нескольких кГц до сотни кГц. Описан принцип работы преобразователя частоты.

**Ключевые слова:** индукционный нагрев, преобразователь частоты, транзистор, энергоэффективность и КПД.

#### Information about the authors:

Isembergenov N. T. – doctor of Technical Sciences Professor Kazakh national research technical university named after K. I. Satpayev, Almaty, Kazakhstan

Alsatova A. N. – master Kazakh national research technical university named after K.I. Satpayev, Almaty, Kazakhstan