

NEWS

OF THE NATIONAL ACADEMY OF SCIENCES OF THE REPUBLIC OF KAZAKHSTAN

SERIES OF GEOLOGY AND TECHNICAL SCIENCES

ISSN 2224-5278

Volume 2, Number 428 (2018), 44 – 54

UDC 637.02

G. V. Zhdankin¹, O.V. Mikhailova², V. G. Semenov³, D. A. Baimukanov⁴, K. Zh. Iskhan⁵,
M. B. Kalmagambetova⁴, S. D. Nurbayev⁴, Kh. A. Aubakirov⁶

¹State Federal-Funded Educational Institution of Higher Professional Training
"Nizhny Novgorod State Agricultural Academy", Nizhny Novgorod, Russia,

²State-Funded Educational Institution of Higher Professional Training

"Nizhny Novgorod State Engineering and Economic University", Knyaginino, Nizhny Novgorod Region, Russia,

³State Federal-Funded Educational Institution of Higher Professional Training

"Chuvash State Agricultural Academy", Cheboksary, Russia,

⁴Limited Liability Partnership "Kazakh Scientific Research Institute of Animal Breeding and Fodder Production",
Almaty, Kazakhstan,

⁵Non-commercial Joint-Stock Company "Kazakh National Agrarian University", Almaty, Kazakhstan,

⁶Taraz State University named after M. Kh. Dulati, Taraz, Kazakhstan.

E-mail: gdankin@inbox.ru ds17823@yandex.ru semenov_v.g@list.ru dbaimukanov@mail.ru kairat@mail.ru
animal_feeding@mail.ru sdnurbaev@mail.ru hamit_a57@mail.ru

MICROWAVE INSTALLATION WITH CONICAL RESONATORS FOR THE HEAT TREATMENT OF INEDIBLE MEAT WASTES

Abstract. *The aim of the research* is to develop ultrahigh-frequency installations and technologies for heat treatment of inedible wastes of animal origin in a continuous mode to increase the feed value of the protein product. In connection with the aim, the main objectives were solved, which allowed to manufacture and test in the production conditions of microwave installations for the heat treatment of inedible wastes of animal origin and to assess the technical and economic efficiency of their introduction into farms.

The objects of research are the technological processes that provide heat treatment of multicomponent raw materials, experimental and test samples of ultra-frequency installations. The subject of research is the detection of laws of the influence of the electromagnetic field of ultrahigh frequency on multicomponent raw materials of high humidity for determination of effective operating modes of functioning of ultrahigh-frequency installations in the continuous mode.

For the implementation of microwave technology for the heat treatment of multicomponent highly-humid raw material multi-generating radio-leak-tight installations with a low-power magnetron air cooling, ensuring the continuity of the technological process and the repeated impact of EMF of UHF, at sufficiently high electric field intensity and the own Q-factor of the resonator was developed. The configuration of the working chambers provides for the possibility of ensuring uniform heating of raw materials and varying the productivity of the installation, with the implementation of its sanitary processing.

There were developed two microwave setups with a conical resonator for the heat treatment and disinfection of inedible wastes of animal origin, providing the high electric field, the continuity of the technological process in compliance with radio leak-tightness.

Keywords: microwave generator, magnetron, biconical and tetraconical resonators, inedible wastes of animal origin, heat treatment and disinfection, continuous mode.

Introduction. In accordance with the strategy for the development of the Russian Federation processing industry until 2020 and the Federal Scientific and Technical Program for the Development of Agriculture for 2017–2025, approved on August 25, 2017, No. 996, which provide for the tasks of ensuring the import substitution of biological supplements by increasing their own production and increasing the efficiency of technology for processing inedible wastes of animal origin, the development of scientifically-based technology and technical means to increase the feed value is *relevant*.

It is known that in birds and animals killing process with subsequent processing, technical waste is accumulated, characterized by a high moisture content (65–75%) directed to the production of animal feed. Due to the high humidity content, the raw material is a good medium for the development of microorganisms, therefore all inedible wastes of animal origin should be processed for the destruction of pathogenic microflora [1].

It is distinguished a method for producing a meat-and-bone meal from animal slaughter wastes in vacuum boilers by steam hydrolysis, sterilization and further drying of the raw materials. Due to the duration of the contact of the raw material with the high-temperature fluid, the quality of the feed product decreases. Such a technology is not easy to implement in a recycling workshop with low productivity. The technology of production of feed flour from blood is known, where the main processes are carried out in vacuum boilers, at high energy costs (30 kWh/t of raw materials) and steam (1200 kg/t of raw materials) [2].

Therefore, for small and medium-sized agricultural enterprises, the development of technologies and technical means for the heat treatment of inedible wastes of animal origin, which allow to decontaminate the product, is *relevant*.

We propose technologies and technical means for the heat treatment of inedible wastes of animal origin in the electromagnetic field of ultrahigh-frequency (EMF UHF) to increase the feed value of the protein supplement with reduced operating costs [3-9]. To implement such a technology, installations with ultrahigh-frequency (microwave) power supply were developed [10-18].

In Russia, the importance of the development of research for the effects of ultrahigh-frequency (microwave) heating is confirmed by the adoption on December 17, 2012, of the Strategic Research Program "UHF Technologies", which determines the development of industrial process heaters.

It is known that in the USA, England, Canada, Germany and France, UHF installations are developed on the basis of one or several sources of microwave energy, power from 25 to 50 kW. Such installations have considerable dimensions and weight, water cooling devices and magnetron protection facilities from reflected power (ferrite circulators), but they do not ensure uniform heating of the raw materials [19-25]. When one source fails, it is necessary to stop the whole technological process. The cost of installed UHF power is estimated at \$2500–3000 per 1 kW. Therefore, for the widespread introduction of microwave installations in agricultural production, the cost of installed microwave power should be reduced to an average of \$100–300 dollars [10].

The scientific problem is the increase in the efficiency of the operation of microwave installations providing heat treatment and disinfection of inedible wastes of animal origin with the increase in the nutritional value of the protein supplement.

Technologies and technical means for inedible waste processing have been studied by such authors as Rogov I.A., Ivashov V.I., Boltenkov I.M., Kurochkin A.A. They have developed technological lines for the production of dry animal feeds from blood, fat, bones, etc. [2].

A major contribution to the theory of heat exchange processes and the theory of electromagnetic fields was made by Arkhangelskiy Yu.S., Atabekov G.I., Bessonov L.A., Bunimovich V.I., Ginzburg A.S., Drobakhina O.O., Kisunko G.V., Kolomeitsev V.A., Lykov A.V., Lurye M.Yu., Netushil A.V., Neiman M.S., Rudobashta S.P. and etc. [11, 24].

The founders of innovative electrotechnologies are Borodin I.F., Strebkov D.S., Prischep L.G. and others. Works continue on the development and improvement of microwave technology and hardware by Vasilyev A.N., Vendin S.V. and etc. [12, 13].

However, the task of increasing the nutritional value of protein additives by the action of electromagnetic radiation in the continuous mode, with the use of low-power ultrahigh-frequency generators, remains unsolved. Analysis of the results of studies carried out by many authors [11, 10] on the implementation of electrophysical methods of action on raw materials of animal origin, including on inedible animal slaughter wastes, makes it possible to identify the main directions for improving microwave technology.

The aim of the research is the development of microwave installations and technology of the heat treatment of non-food wastes of animal origin in a continuous mode to increase the feed value.

In connection with the aim, the following objectives are set:

1. To develop technologies for processing inedible wastes of animal origin by repeated exposure by EMF UHF, providing an increase in the nutritional value of the protein product;

2. To expand the research of the method of EMFUHF influence on multicomponent raw materials in non-traditional resonators and to obtain mathematical models of the process of functioning of installations ensuring the continuity of the technological process of cooking and disinfection of inedible wastes of animal origin with rational engineering and technological parameters;

3. To derive analytical dependencies that allow us to justify the parameters of the electrodynamic system with non-traditional resonating chambers that ensure the cooking and improvement of the microbiological parameters of the protein product;

4. To study the distribution pattern of the electromagnetic field of the ultrahigh-frequency and the heat flux in the resonators that ensure a continuous mode of operation of microwave installations;

5. To develop a technique for designing microwave installations based on the derived analytical dependencies and the equation of the dynamics of endogenous heating of multicomponent raw materials at changing in the electrophysical parameters during the heat treatment;

6. To substantiate the complex of engineering and technological parameters and operating modes of microwave installations taking into account the revealed dependencies and results of studies of physico-chemical, microbiological and organoleptic indices characterizing the nutritional value of a protein product;

7. To develop, manufacture and test the UHF installations for heat treatment of inedible wastes of animal origin in industrial conditions and to assess the technical and economic efficiency of their introduction into farms; to develop scientifically grounded practical recommendations on the development of installations with ultrahigh-frequency power supply to reduce operating costs and increase the feed value of protein products; to develop a technical task for creating a sample of microwave installations for the heat treatment and disinfection of inedible wastes of animal origin in the continuous mode.

Methods of the research. The investigations were carried out on the basis of the theory of the electromagnetic field using mathematical apparatuses of electrodynamics. The processing of the experimental data was carried out using computer programs such as Microsoft Excel 10.0, Statistic 5.0, 3D modeling of the design of microwave installations in the Compass-3DV15 program. Calculations and visualization of the distribution of the electromagnetic field in the developed resonators were carried out according to the programs of three-dimensional computer simulation of the electric field CST StudioSuite 2015 and its subroutine CST Microwave Studio. Experimental studies of the process of repeated exposure of EMFUHF to raw materials were carried out using electronic digital recording equipment. The model of separation of raw materials into a solid and liquid fraction was made in the program FlowVision 2.5. A multicriterial evaluation of the technological process of the EMFUHF effect on raw materials was carried out through regression models obtained on the basis of the theory of active planning of the three-factor experiment of type 23 in the Statistic 8.0, Excel 10.0 programs. The quality of the processed product was evaluated through organoleptic, physicochemical and microbiological indicators in specialized laboratories and using the SpectraStar 2400 infra-red analyzer. Three-dimensional modeling of the design of microwave installations was carried out in the Compass-3DV15 program.

Results of the research. To reduce the operating costs of the technological process for the production of a protein product from inedible wastes of animal origin, it is proposed to heat-treat in EMFUHF the raw materials, previously crushed and dehydrated. To implement the microwave technology for processing multicomponent highly-humid raw materials, various non-traditional configurations of volume resonators have been developed that ensure the implementation of the following criteria [14]:

1. Continuity of the technological process of EMFUHF;

2. High electric field intensity, achieved due to the use of a special configuration of resonators and several sources of radiation in one resonator, providing multiple exposure of EMFUHF to raw materials, increasing the bactericidal effect;

3. High basic Q of resonator, at which the high efficiency of the installation is achieved, due to special camera configurations;

4. The radio-leak-tightness of the installation, due to the use of a shielding body made of non-ferromagnetic material and below-cutoff waveguides, instead of receiving and discharge sleeves;

5. Variability of installation efficiency and versatility for multicomponent raw materials with high humidity, achieved through the use of several low-power air-cooling magnetrons;

6. Uniform distribution of the electric field and inedible waste in the resonator;
7. Possibility of sanitary treatment of the working chamber after the heat treatment of raw materials.

The following describes the developed microwave installations containing conical resonators that allow to create a high electric field intensity and continuity of the technological process while maintaining the maximum permissible level of radio-leak-tightness.

1. Ultrahigh-frequency installation with a biconical resonator for the heat treatment of inedible wastes of animal origin. It is known that an open biconical resonator is used to increase the radiative Q-factor, the cross-section of which decreases from the center to the edges [12, 13]. In the middle part of such a resonator, there are waves propagation constants of which decrease in the case of removal from the center of the resonator. When the diameter of the open end of the resonator reaches certain limiting values, which can be characterized by the value of half of the diameter of the base of the conical components of the resonator, the quality factor of the resonator decreases significantly and its application loses its meaning [22-24].

A characteristic feature of the biconical resonator is the presence of areas with a pronounced exponential law of variation of the electromagnetic field. Such a field distribution allows to remove a part of the surface without significant Q-factors for some types of oscillations and thereby realize an open resonance system. The biconical resonator, in comparison with a cylindrical resonator [14, 25], excludes the degeneracy of parasitic modes, and this allows high Q values to be achieved. By choosing the angle at the tip of the cone, it is possible to form an electromagnetic field concentrated mainly in the central area of the resonator, and this contributes to a greater increase in the Q-factor of the resonator [3, 12].

The developed microwave installation with the biconical resonator (figure 1) has a sufficiently high intrinsic Q-factor, radio-leak-tightness, and where it is possible to excite an electric field of high intensity. The main units of the installation are the biconical resonator 5, microwave generators, a screw conveyor 3, 4 with a motor reducer 1 and a charging capacity 2. Inside the horizontally arranged biconical resonator 5, the screw conveyor 3,4 is mounted coaxially along its central axis. It is made in the form of a cylindrical dielectric body 4 with a screw dielectric conveyor 3. The hole on one vertex of the circular cone 5 and the end of the cylindrical dielectric body 4 are docked to the lower base of the charging capacity 2. The continuation of the screw dielectric conveyor 3 is located in the charging capacity 2 and is connected to the shaft of the geared motor 1. The geared motor 1 for driving the conveyor is mounted on the outside of the charging capacity 2. This container 2 is made of a non-ferromagnetic material. The diameter of the hole at the other vertex of the circular cone (biconical resonator 5) is less than a quarter of the wavelength, then the radiation is limited. Magnetrons 6 of microwave generators are installed along the perimeter of the joint of the bases of circular cones, with a shift of 120 degrees. In the area of the vertices of circular cones in the biconical resonator, an electric field of high intensity is excited. This means that when the high-intensity electric field of the ultrahigh frequency is double-acting, the bacterial microflora is destroyed, i.e. sterility of the welded protein food for animals is provided.

Continuity of the technological process is provided by means of the screw 3 made of a dielectric material, for example, a fluoroplastic.

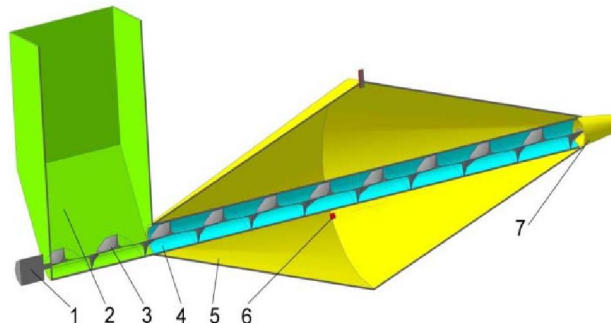

Figure 1 – Ultrahigh-frequency installation with the biconical resonator for the heat treatment and disinfection of wastes of animal origin: 1 – geared motor for driving the dielectric screw; 2 – charging capacity for crushed raw materials; 3 – screw conveyor; 4 – cylindrical screw body; 5 – biconical resonator; 6 – magnetrons of the microwave generator; 7 – discharge hole on the top of the circular cone

The screw conveyor consists of a cylindrical dielectric body 4, inside which a dielectric screw 3 with a spiral rib rotates. On the tops of cones with a common base of circular section, there are holes for feeding raw materials and unloading finished products in a continuous mode. If the diameter of these holes is less than a quarter of the wavelength, then the installation meets the requirements of radio-leak-tightness, i.e. the maximum permissible level of the radiation power flux does not exceed the normative value. The design parameters of the conical resonator are consistent with the wavelength.

The technological process of the heat treatment of animal slaughter wastes in a continuous biconical resonator occurs as follows. Load the crushed inedible waste loading container 2. Switch on the geared motor 1 for driving the screw conveyor 3, 4. When the screw dielectric conveyor 3 rotates, the spiral ribs push the raw material along the dielectric cylindrical body 4. Switch on the microwave generators, the emitters from the magnetrons 6 directed into the biconical resonator 5 excite the electromagnetic field in it. Moreover, the intensity of the electric field of the ultrahigh-frequency in the biconical resonator increases from the center to the vertices of the circular cones. Therefore, when the raw material is transported by means of the screw conveyor through the biconical resonator 5, the raw material is exposed to an electric field of immediately high tension with a gradual decrease to the central part of the resonator, then with an increase in the electric field strength to the discharge hole. Such a double action of the electric field with a smooth change in the intensity from a minimum to a maximum ensures the destruction of pathogenic microorganisms and equalization of the temperature of the raw material in the interstitial space of the screw conveyor during its movement and mixing. This ensures uniform dielectric heating and heat treatment of the raw materials. The principle of action of the conveyor from a dielectric material is based on the use of a rotating screw, the spiral ribs of which move the raw material located in the areas between the cylindrical body and the screw of the conveyor. The rotation of the conveyor is transferred from the geared motor on the side of the charging capacity 2. The use of such screw conveyor is due to the physical properties of the inedible animal slaughter wastes and the possibility of maintenance of the electric drive. The screw conveyor drive is carried out by means of the geared motor, which allows to regulate the speed of rotation, to regulate the duration of the movement of the raw materials through the biconical resonator. The cylindrical body of the conveyor 4 is made of a dielectric material. The dimensions of the body 4 (diameter and length) are matched to the dimensions of the biconical resonator, which in turn are matched to the wavelength. The shape and execution of the delivery screw conveyor largely depend on the physical and mechanical properties of the raw materials.

The capability of the installation depends on the number of microwave generators and the dose ($W \cdot s/g$) of the effect of the electromagnetic field of the ultrahigh frequency (EMFUHF), i.e. the product of the specific power of the generator (W/g) and the duration of the exposure (s).

2. Ultrahigh-frequency installation with conical resonators for the heat treatment of inedible meat wastes. The main nodes of the microwave installation (figure 2) are the spherical shielding body 11, the conical resonators with round bases 3 and UHF generators 2 of low power. The working chamber is presented in the form of conical resonators, the round bases of which are docked with the spherical shielding body. In the upper part of the hemisphere, there is a loading spout 1. Conical resonators are docked uniformly along the perimeter of the lower hemisphere. For this, there are holes in the shielding body in the area of the lower hemispheres. In this case, the axes of the conical resonators are an extension of the radial axes of the spherical body, inside which a disk 8 rotating from the shaft 9 is coaxially mounted. On the disc, there are directional vanes, and under the disk - pushers 10. The disk, directional vanes, pushers are made of dielectric material. The vanes are located along the radial axes of the disc. The pushers and thrust elements provide vibration to the dielectric tray 4.

UHF generators are installed at the joints of the spherical shielding body and circular conical resonators 3. At the tops of the conical resonators, there are discharge holes 5. To maintain the radio-leak-tightness of the microwave installation, the diameter of the discharge hole cannot exceed a quarter of the wavelength. The diameter of the spherical shielding body and the design parameters of the conical resonators are matched to the wavelength.

The technological process of the heat treatment of animal slaughter wastes in the continuous mode is as follows. Turn on the electric drive of the disc, the crushing mechanism that feeds the crushed inedible wastes into the working chamber through the loading spout 1, which is presented on the spherical body 11. Next, switch on the microwave generators 2. The raw materials fall on the rotating dielectric disk 8 and

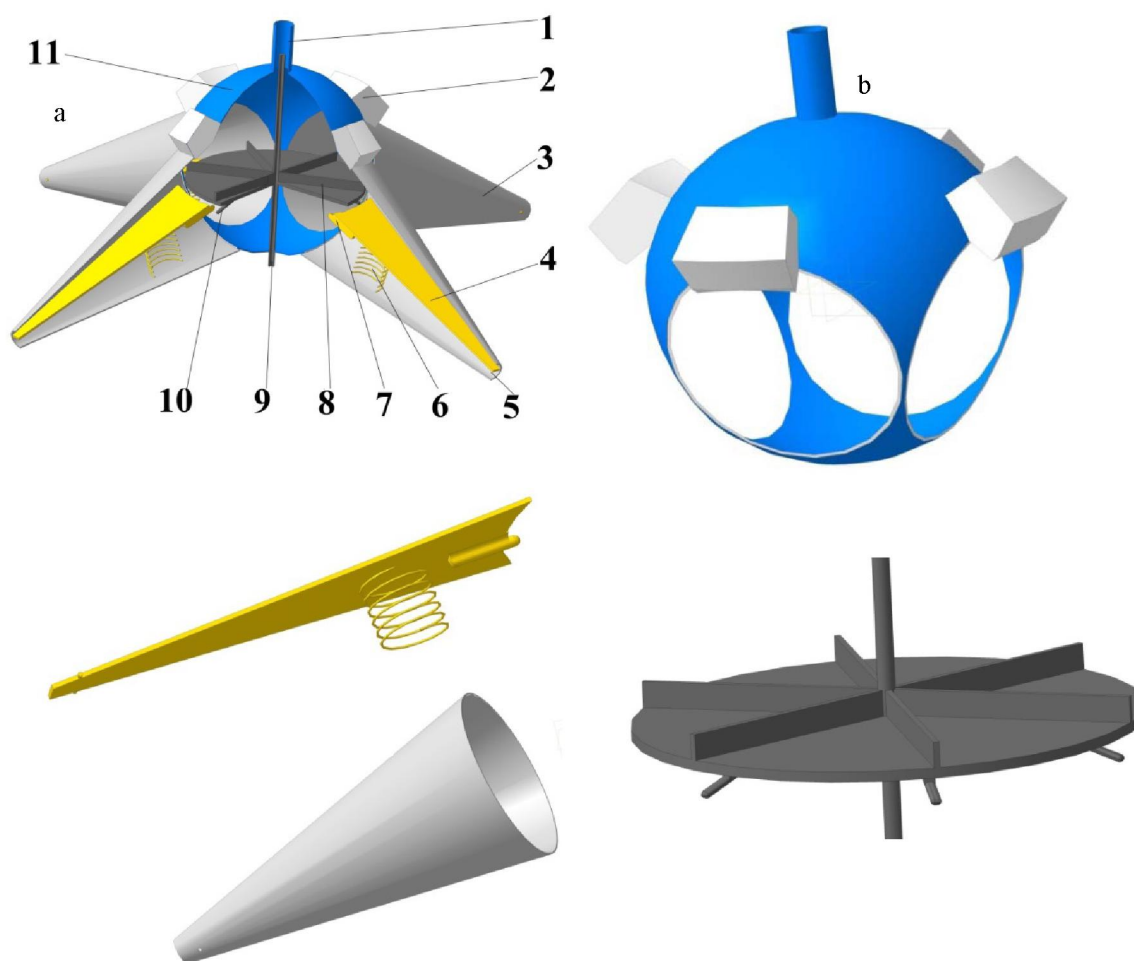

Figure 2 – Microwave installation with conical resonators for the heat treatment of inedible meat raw materials in continuous mode: a – general view; b – spherical shielding body with UHF generators; c – directional tray with a spring; d – conical resonator; e – disk, 1 – loading spout; 2 – microwave generator; 3 – circular conical resonator; 4 – dielectric directional tray; 5 – discharge hole; 6 – spring with a radio-absorbing coating; 7 – stop element; 8 – dielectric disk with directional vanes; 9 – shaft of the electric drive; 10 – dielectric pusher; 11 – spherical shielding body

with the help of the directional vanes, due to the centrifugal force, is reset to dielectric trays. In the working chamber (in sphere 11 and in the conical resonators 3), the electromagnetic field of ultrahigh frequency is excited. The raw material, when moving along dielectric disc 8 and along dielectric trays 4, is heated, cooked and disinfected in the continuous mode. In this case, the dielectric trays, due to the stop elements 7 and the pushers 10, are raised to the level of the dielectric disc 8 and lowered, and due to the vibration of the spring 6, the raw materials along the dielectric trays move to the discharge holes 5.

A nomogram (figure 3) has been developed that allows to reconcile the design parameters with the installation operation modes depending on the initial bacterial number of the raw materials (TMC); to coordinate the exposure dose of EMFUHF, the specific power of the generator and the increment of the heating temperature; determine the performance of the installation.

During the heat treatment of inedible waste of animal slaughter in EMFUHF the following processes occur: hydrolysis of starch and its dextrinization, thereby increasing accessibility; chemical modification of dietary fiber; increase the stability of fat due to the destruction of enzymes, which increases the shelf life of the product. Under the influence of EMFUHF, the raw materials are modified, i.e. it is stabilized in composition and completely sterilized. Microwave installation allows to efficiently process all generated waste slaughter and deboning to obtain an effective feed product. The composition of the product depends on the type of processed meat wastes.

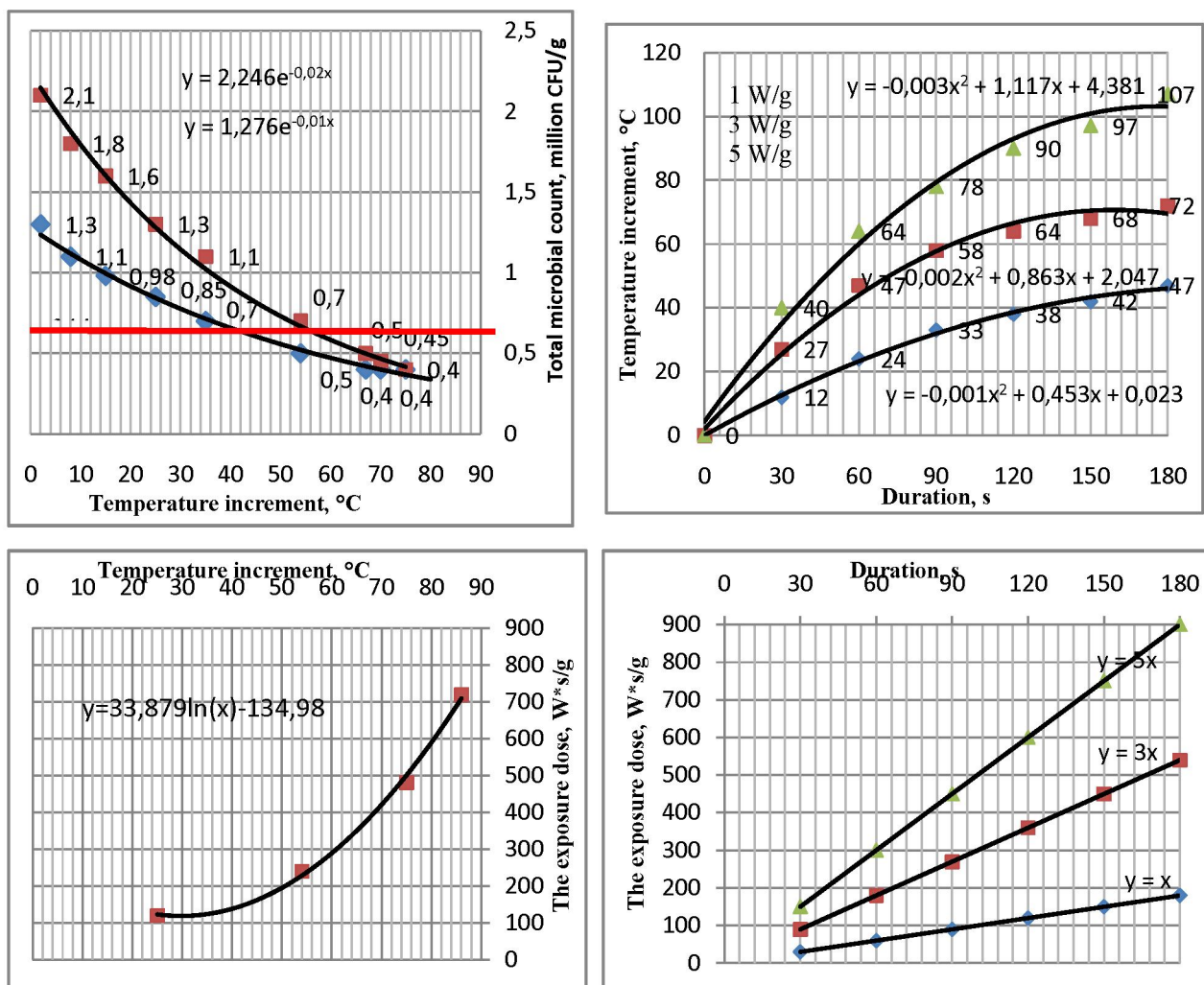

Figure 3 – Nomogram for reconciling of the regime parameters of the microwave installations with the optimization criterion - with the decrease in the TMC in the raw materials

Specifications of microwave installations for the heat treatment of inedible wastes of animal origin in the continuous mode with conical resonators are given in Table.

Specifications of microwave installations with conical resonators

Name	Parameters
Capability, kg/h	40–50
Power of microwave generators, kW	4.8
Drive power of disk, kW	0.5
Power of microwave installation, kW	5.3
Specific energy costs, kW*h/kg	0.11–0.13
Dimensional specifications, m	2.0-1.0

Conclusion.

1. The developed operational and technological schemes for the heat treatment and disinfection of inedible meat raw materials by the action of the electromagnetic field of ultrahigh frequency and structural schemes ensure the implementation of microwave technology in the continuous mode with observance of the electromagnetic safety of installations estimated by the value of the radiation flux power not exceeding $10 \mu\text{W}/\text{cm}^2$, working 8 hours per day.

2. The deduced mathematical dependences of the heating dynamics of inedible meat raw materials with a change in the electrophysical parameters in the process of the EMFUHF effect allow us to reconcile the design and technological parameters with the operation modes of the microwave installations, namely:

basic Q-factor (4000) and the volume of the resonator with electric field strength (2.89 kV/cm) and heating rate (0.6–0.8°C/s) of the raw materials of different humidity (65–80%).

3. The distribution of the electromagnetic field in the transient process in conical resonators is calculated and visualized with the help of the CST Microwave Studio program. The results made it possible to comprehensively evaluate the change in the parameters of the electrodynamic system "generator-resonator-load".

4. Based on the analysis of regression models and evaluation of the chemical composition of the protein product, rational design and technological parameters and operating modes of the microwave installation have been revealed. The UHF installation for the heat treatment and disinfection of inedible animal slaughter wastes consumed by the power of 4.28 kW is designed and manufactured, providing a capability of up to 30 kg/h at the energy cost of 0.15 kW·h/kg. The microbiological parameters of the raw material with the initial bacterial number of $2 \cdot 10^6$ CFU/g and the heat treatment in EMFUHF to 100°C improved to $0.2 \cdot 10^6$ CFU/g. The chemical composition of the processed product corresponds to the normative data.

5. The economic effect of the use of microwave installation for the heat treatment and disinfection of inedible meat raw materials in the continuous mode is within 400 thousand rubles per year due to a reduction in operating costs.

The scientifically grounded practical recommendations for the creation and operation of microwave installations for the heat treatment and disinfection of inedible meat raw materials have been developed.

The obtained results can be successfully used for the heat treatment and disinfection of inedible meat raw materials in dairy cattle breeding, in the male young-stock breeding [15-18].

REFERENCES

[1] Kadyrov D.I., Garzanov A.L. Extrusion processing of biological waste into feeds // Poultry farming. 2008. N 7. P. 51-54 (in Russ.).

[2] Ivashov V.I. Technological equipment of meat industry enterprises. M.: Kolos, 2001. 552 p. (in Russ.).

[3] Belova M.V., Zhdankin G.V., Novikova G.V. Development of microwave container-type installation for heat treatment of blood and fat-containing raw materials // Bulletin of Kazan State Agrarian University. Kazan, 2016. N 4(42). P. 74-78 (in Russ.).

[4] Zhdankin G.V., Ziganshin B.G., Belova M.V. Development and justification of the parameters of microwave installation with a spherical resonator for heat treatment of boil wastes // Bulletin of the Kazan State Agrarian University. Kazan, 2017. N 5. P. 109-114 (in Russ.).

[5] Zhdankin G.V., Ziganshin B.G., Belova M.V. Development of a multimodule microwave installation for heat treatment of raw materials of animal origin // Vestnik Kazan SAU. Kazan: KSAU, 2016. N 4(42). P. 79-83 (in Russ.).

[6] Zhdankin G.V., Novikova G.V., Ziganshin B.G. Development of working chambers of ultrahigh-frequency installations for heat treatment of inedible wastes of meat production // Vestnik of the Izhevsk State Agricultural Academy. Izhevsk: Izhevsk State Agricultural Academy, 2017. N 1(50). P. 61-69 (in Russ.).

[7] Zhdankin G.V., Storchevov V.F., Ziganshin B.G., Novikova G.V. Development and substantiation of the parameters of a multi-tier microwave installation for heat treatment of wet raw materials in the continuous mode // Scientific life. 2017. N 4. P. 4-14 (in Russ.).

[8] Patent No. 2541634 of the Russian Federation, IPC A23J1/06. A method for heat treatment of blood of agricultural animals. M.V. Belova, A.A. Belov, I.G. Ershova, N.T. Uyezdnyy, G.V. Novikova, O.V. Mikhailova; applicant and patent owner of the State Agricultural Academy (RU). No. 2013146767; claimed. 10/18/2013. Bul. № 5 of 20.02.2015. 7 p. (in Russ.).

[9] The patent № 2629259 of the Russian Federation, IPC A23K 1/10. Ultrahigh-frequency installation for cooking of poultry and animal slaughter wastes / G.V. Zhdankin, G.V. Novikova; applicant and patent owner of the NNSAA (RU). No. 2016146640; claimed. 11/28/2016. Bul. № 25 of August 28, 2017. 10 p. (in Russ.).

[10] Kolomeitsev V.A., Komarov V.V. Microwave installations with uniform volumetric heating. Part 2. Saratov: CSTU, 2006. 233 p. (in Russ.).

[11] Didenko A.N. UHF power engineering: theory and practice. M.: Science, 2003. 447 p. (in Russ.).

[12] Drobakhin O.O., Zabolotny P.I., Privalov E.N. Resonance properties of axially symmetric microwave cavities with conical elements // Radiophysics and Radio Astronomy. 2009. Vol. 1, N 4. P. 433-441 (in Russ.).

- [13] Strekalov A.V., Strekalov Yu.A. Electromagnetic fields and waves. M.: RIOR: INFRA-M, 2014. 375 p. (in Russ.).
- [14] Shamin E.A., Ziganshin B.G., Novikova G.V. Development of ultrahigh-frequency installation with cylindrical resonators for drying down and fur raw materials in the continuous mode // Vestnik NIGIER. Knyaginino: GBOU V NGIEU, 2017. N 9(76). P. 57-64 (in Russ.).
- [15] Begaliyeva D.A., Alentayev A.S., Ombayev A.M., Baimukanov D.A. Improvement of the Technology for Young-Stock Breeding of Black-and-White Dairy Cattle in the Southeast of Kazakhstan // OnLine Journal of Biological Sciences (<http://thescipub.com/abstract/10.3844/ofsp.11376>), 2017, DOI: 10.3844/ojbsci.2017.
- [16] Alentaev A.S., Smailov S.D., Baimukanov D.A., Abdрахманов K.T. Productivity of the factory type "ADAL" of black-and-white cattle of JSC "Agro-industrial company" ADAL // J. Bulletin of the National Academy of Sciences of the Republic of Kazakhstan. Almaty, 2017. N 5. P. 125-140 (in Russ.).
- [17] Begaliyeva D.A., Baimukanov D.A., Alentaev A.S. Influence of the technology of directed growth of the dumpling of dairy breeds on the formation of productivity // Studies, results. Almaty: KazNAU, 2017. N 4. P. 45-51 (in Russ.).
- [18] Ombayev A.M., Begaliyeva D.A., Alentaev A.S., Baimukanov D.A. Intensive technologies of directed growth of young dairy breeds in Akmola and Almaty regions // Research, results. Almaty: KazNAU, 2017. N 4. P. 166-170 (in Russ.).
- [19] Makimoto M., Yamashita S. Microwave resonators for wireless communication. Theory, design and application. Berlin: Springer – Verlag, 2001. 162 p.
- [20] Harrington R. F. Time-harmonic electromagnetic fields. New York: Wiley, 2001. 480 p.
- [21] Sherstnev V.V., Krier A., Monakhov A.M., Hill G. // Electron. Lett. 2003. Vol. 39. P. 916.
- [22] Sidoruk V.A., Fiorani F., Jahnke S., Krause H.-J. Design and characterization of microwave cavity resonators for noninvasive monitoring of plant water distribution. IEEE Trans. Microwave Theory Tech. 2016. Vol. 64, N 9. P. 2894-2904. DOI: 10.1109/TMTT.2016.2594218.
- [23] Drobakhin O.O., Privalov Ye.N., Saltykov D.Yu. Open-ended waveguide cutoff resonators for monitoring dielectrics parameters of gases. Telecommun. Radio Eng. 2013. Vol. 72, N 7m P. 627-640. DOI: 10.1615/TelecomRadEng.v72.i7.60.
- [24] Kuryliak D.B., Nazarchuk Z.T., Trishchuk B.O. Axially-symmetric TM-waves diffraction by sphere-conical cavity. PIER B. 2017. Vol. 73. P. 1-16. DOI: 10.2528/PIERB16120904.
- [25] Kuryliak D.B., Sharabura O.M. Diffraction of axially-symmetric TM-wave from Bi-cone formed by finite and semi-infinite shoulders // Progress In Electromagnetics Research B. 2016. Vol. 68. P. 73-88. DOI:10.2528/PIERB16041302.

**Г. В. Жданкин¹, О. В. Михайлова², В. Г. Семенов³, Д. А. Баймуханов⁴,
К. Ж. Исхан⁵, М. Б. Қалмағамбетов⁴, С. Д. Нурбаев⁴, Х. А. Әубәкіров⁶**

- ¹Нижегород мемлекеттік ауыл шарушылық академия, Нижний Новгород, Ресей,
²Нижегород мемлекеттік экономикалық-инженерлік университет, Княгино, Ресей,
³Чуваш мемлекеттік ауыл шаруашығы академиясы, Чебоксары, Ресей,
⁴ЖШС «Қазақ мал шаруашылығы және азық өндірісі» ҒЗИ, Алматы, Қазақстан,
⁵Қазақ ұлттық аграрлық университеті, Алматы, Қазақстан,
⁶Тараз ұлттық университеті М. Х. Дулати атындағы, Тараз, Қазақстан

ТАҒАМДЫҚ ЕМЕС ЕТ ҚАЛДЫҚТАРЫН ТЕРМОӨНДЕУГЕ АРНАЛҒАН КОНУСТЫ РЕЗОНАТОРЛЫ МИКРОТОЛҚЫНДЫ ҚҰРЫЛҒЫЛАР

Аннотация. Зерттеу мақсаты Ақуызды өнімнің азықтық құндылығын арттыру үшін азықтық емес жануар шығу тегіне ие қалдықтарды үздіксіз режимде термоөндеу технологиясы мен жоғары жиілікті құрылғыларды жасау болып табылады. Қойылған мақсатқа сәйкес өндірістік жағдайларда азықтық емес жануар шығу тегіне ие қалдықтарды термоөндеу үшін ЖЖ құрылғылар орнатылған және оларды шаруа қожалықтарына енгізудің техникo-экономикалық тиімділігі бағалалды.

Зерттеу нысаны көпкомпонентті шикізаттың термоөндеуін қамтамасыз ететін технологиялық процестер, ЖЖҚ экспериментальды және сынамалы үлгілері.

Зерттеу үлгісі (предмет) Үздіксіз режимдегі ЖЖҚ тиімді жұмыс жасау режимдеріне жоғары жиіліктегі электромагнитті жазықтың ылғалдылығы жоғары көпкомпонентті шикізатқа әсер ету заңдылықтары зерттеледі.

Көпкомпонентті ылғалдылығы жоғары шикізатты термоөндеудің микротолқынды технологисын іске асыру үшін көпгенераторлы радиогерметикалық қуаттылығы аз магнетронды ауалы салқындатқышты, технологиялық процестің үздіксіздігін қамтамасыз ететін құрылғылар жасалды. ЖЖЭМЖ, электрлі жазықтың жоғары қуаттылығында және резонатордың сапалылығында тиімділігі жоғары. Жұмыс камераларының

конфигурациясында шикізатты бір қалыпты жылыту және құрылғының өнімділігін басқару қарастырылған, санитарлық өңдеу жасалады.

Жануар шығу тегіне ие тағамдық емес қалдықтарды термоөңдеудің және залалсыздандырудың жоғары жиілікті конусты резонаторлы екі құрылғысы сипатталған. Радиогерметиканы сақтағанда технологиялық процестің үздіксіздігін қамтамасыз етеді.

Түйін сөздер: жоғары жиілікті генератор, магнетрон, биоконусты және тетраконусты резонаторлар, жануар шығу тегіне ие тағамдық емес қалдықтар, термоөңдеу және майсыздандыру, үздіксіз режим.

**Г. В. Жданкин¹, О. В. Михайлова², В. Г. Семенов³, Д. А. Баймуканов⁴,
К. Ж. Исхан⁵, М. Б. Калмагамбетов⁴, С. Д. Нурбаев⁴, Х. А. Аубакиров⁶**

¹Федеральное государственное бюджетное образовательное учреждение высшего образования «Нижегородская государственная сельскохозяйственная академия», Нижний Новгород, Россия,

²Государственное бюджетное образовательное учреждение высшего образования «Нижегородский государственный инженерно-экономический университет», Нижегородская область, Княгинино, Россия,

³Федеральное государственное бюджетное образовательное учреждение высшего образования «Чувашская государственная сельскохозяйственная академия», Чебоксары, Россия,

⁴Товарищество с ограниченной ответственностью «Казахский научно-исследовательский институт животноводства и кормопроизводства», Алматы, Казахстан,

⁵Некоммерческое акционерное общество «Казахский национальный аграрный университет», Алматы, Казахстан,

⁶Таразский государственный университет им. М. Х. Дулати, Тараз, Казахстан

МИКРОВОЛНОВЫЕ УСТАНОВКИ С КОНИЧЕСКИМИ РЕЗОНАТОРАМИ ДЛЯ ТЕРМООБРАБОТКИ НЕПИЩЕВЫХ МЯСНЫХ ОТХОДОВ

Аннотация. Целью исследований является разработка сверхвысокочастотных установок и технологии термообработки непищевых отходов животного происхождения в непрерывном режиме для повышения кормовой ценности белкового продукта. В связи с поставленной целью решены основные задачи, позволившие изготовить и апробировать в производственных условиях СВЧ установки для термообработки непищевых отходов животного происхождения и оценить технико-экономическую эффективность их внедрения в фермерские хозяйства.

Объектом исследования являются технологические процессы, обеспечивающие термообработку многокомпонентного сырья, экспериментальные и опытные образцы сверхвысокочастотных установок.

Предметом исследований является выявление закономерностей воздействия электромагнитного поля сверхвысокой частоты на многокомпонентное сырье высокой влажности для определения эффективных рабочих режимов функционирования сверхвысокочастотных установок в непрерывном режиме.

Для осуществления микроволновой технологии термообработки многокомпонентного высоковлажного сырья разработаны многогенераторные радиогерметичные установки с маломощными магнетронами воздушного охлаждения, обеспечивающие непрерывность технологического процесса и многократное воздействие ЭМП СВЧ, при достаточно высокой напряженности электрического поля и собственной добротности резонатора. В конфигурации рабочих камер предусмотрены возможности обеспечения равномерного нагрева сырья и варьирования производительностью установки, с осуществлением ее санитарной обработки.

Описаны две разработанные сверхвысокочастотные установки с коническими резонаторами для термообработки и обеззараживания непищевых отходов животного происхождения, обеспечивающие высокую напряженность электрического поля, непрерывность технологического процесса при соблюдении радиогерметичности.

Ключевые слова: сверхвысокочастотный генератор, магнетрон, биконический и тетраконический резонаторы, непищевые отходы животного происхождения, термообработка и обеззараживание, непрерывный режим.

Information about the authors:

Zhdankin Georgiy Valerievich – Candidate of Economics, associate professor, pro-rector for teaching and methodical work, State Federal-Funded Educational Institution of Higher Professional Training "Nizhny Novgorod State Agricultural Academy"

Mikhailova Olga Valentinovna – Doctor of Engineering Sciences, Associate Professor, Professor of the Department of Information and Communication Technologies and Communication Systems, State-Funded Educational Institution of Higher Professional Training "Nizhny Novgorod State Engineering and Economic University"

Semenov Vladimir Grigorievich – Doctor of Biological Sciences, Professor, Honored Scientist of the Chuvash Republic, Professor of the Department of Morphology, Obstetrics and Therapy, State Federal-Funded Educational Institution of Higher Professional Training "Chuvash State Agricultural Academy"

Baimukanov Dastanbek Asylbekovich – Doctor of Agricultural Sciences, Professor, Corresponding Member of the National Academy of Sciences of the Republic of Kazakhstan, Chief Researcher of the Department of Breeding and Selection of Dairy Cattle, Limited Liability Partnership "Kazakh Scientific Research Institute of Animal Breeding and Fodder Production". E-mail: dbaimukanov@mail.ru

Iskhan Kairat Zhalelovich – Candidate of Agricultural Sciences, associate professor, professor of the department "Technology of production of livestock products" of the faculty "Technology and Bioresources", Non-commercial Joint-Stock Company "Kazakh National Agrarian University". E-mail: kairat@mail.ru

Kalmagambetov Murat Baitugelovich – Candidate of Agricultural Sciences, Head of the Department of Feeding Livestock Animals, Limited Liability Partnership "Kazakh Scientific Research Institute of Animal Breeding and Fodder Production".

Nurbayev Serik Doldashevich – Doctor of Biological Sciences, Professor, Head of Genetics Laboratory, Limited Liability Partnership "Kazakh Scientific Research Institute of Animal Breeding and Fodder Production".

Aubakirov Khamit Abilgazyevich – Candidate of Agricultural Sciences, Associate Professor of the Department of Biotechnology, M.Kh. Dulati Taraz State University, Taraz, Kazakhstan.