

NEWS

OF THE NATIONAL ACADEMY OF SCIENCES OF THE REPUBLIC OF KAZAKHSTAN

SERIES OF GEOLOGY AND TECHNICAL SCIENCES

ISSN 2224-5278

Volume 4, Number 424 (2017), 233 – 236

UDC 537.523.3:541.13

A. A. Abdurrahmanov, S. A. Bahtaev, A. A. Bokanova, U. Mataev

Almaty university of power engineering & telecommunication, Kazakhstan.

E-mail: bokanova_a@mail.ru

DEVICE FOR PURIFICATION OF AIRS OF POULTRY PLANTS

Abstract. Development of efficient, energy-saving technology and innovative technical facilities for the generation and processing (ozone) of premises for poultry, poultry meat and eggs and its introduction into poultry farms in order to increase their profitability and competitiveness. In this regard, we propose an innovative air purification device equipped with negatively charged electrete plates installed alternately and corona electrodes in the form of needles on a grid that are located along the direction of the flow of dusty gas.

Keywords: corona discharge, elektrete plates, ozonizer, electrode, scale.

A significant proportion of all infectious diseases in poultry farming accounts for diseases of bacterial etiology, to which the youngsters are particularly sensitive. At the same time, bacterial diseases very rarely occur as a monoinfection, but are most often caused by associations of microorganisms. It should be noted that the role of (opportunistic) conventional pathogenous microorganisms in the etiology of bacterial diseases is gradually increasing [1-3].

From the reporting data of bacteriological studies in poultry farms, 60% of the total number of positive results are (colibacillosis) colibacterium, 13% - streptococcosis, 12.5% - salmonellosis, 6 2% - staphylococcosis, 6% - pseudomonas, 2% - pasteurellosis, Other (opportunistic) conventional pathogenous microorganisms - 0.5% [2-4].

The refore, antiepizootic measures in poultry farming are not only measures aimed at preventing the introduction and spread of pathogens, but also a control system implemented through the use of drugs that have therapeutic and prophylactic effects, disinfecting ability and a wide spectrum of antimicrobial activities. In addition, disinfection also carries a social burden, providing not only good production indicators of the enterprise, but also a high sanitary quality of the products. In connection with this, the safety requirements for the used disinfectants and their effectiveness, the direction of the action of the method of handling them, also. One of the methods of controlling the spread of infectious diseases is the processing of foodstuffs. As a rule, special chemical preparations are used for these purposes, including medicines and disinfectants, which lead to additional financial costs and losses. It is well known that diseases are easier to prevent than treat. In connection with this, in the world practice, preventive measures aimed at improving the sanitary condition and disinfecting the air of storage facilities, food products, etc., have become widespread. [4-5]. For these purposes, the physical-chemical method of prevention-treatment with ozone is the most suitable. Under the action of ozone, there is a guaranteed destruction of all known microorganisms-bacteria, viruses, fungi, etc. Ozone has a strong oxidizing ability, a powerful bactericidal action and the ability to effectively destroy various kinds of mold fungi and yeast, to destroy bacteria and viruses. Ozone has a pronounced intoxicidal effect. As a result of exposure to ozone, the metabolic products (toxins) and microorganisms are neutralized.

According to available data, when eggs are processed with ozone, the embryo develops more intensively, the growth and total metabolism enhance [1-3].

For example, processing of poultry meat with an ozone - air mixture during its air cooling allows to store chickens-broilers for a long time without deep freezing in the cooled state, as during the freezing the nutritional and taste qualities of meat decrease. Ozonization contributes to the improvement of the

biological value of poultry meat and cattle. Processing of meat with ozone provides high preservation of nutritional and taste qualities of the product, preserves its tenderness, juiciness and moisture capacity [4-6]. To solve the existing problem, several solutions were proposed. One of them is the development of a new device for air purification. The device would allow the creation of modular technological installations for the generation of ozone and for the processing of air in the premises of storage facilities for food products, using innovative technical means in them that will be used in the future.

In the development of processes and apparatuses of ozone technology for cleaning and disinfection of air in storage facilities and food products for long-term storage, as well as processing of meat and eggs, the general situation of objects will be analyzed, monitoring of similar methods will be carried out, a simulation model will be developed that allows to create an expert technological line on the basis of experimental one [7-9].

For creating the simulation model, physical and chemical methods of research were used, i.e. energy-saving technology and ozone output for air treatment of poultry premises largely depend on the energy parameters of the devices in the process line, one of which is an increase in the discharge current, a decrease in the dependence of the ozone output on the variations in atmospheric air, and so on. To determine the interaction of ozone with organic and inorganic compounds, chemical methods of investigation were used [8-10].

The developed discharge device is recommended for prevention and treatment of diseases of bacterial, viral and fungal etiology, as well as for aerosol disinfection of poultry housing in the presence of birds, it has a high efficiency of trapping fine-dispersed aerosol particles, and is characterized by simplicity of construction and simplification of collection of aerosol particles.

Previously, an apparatus was known for trapping fine particles in the air stream that contained a system of coaxially arranged corona and precipitation electrodes, with the same-charged electrodes provided with plugs connecting them [11-12]. Extension of the working zone of the electrostatic precipitator by means of "successive coupling of electric fields in the form of a labyrinth annular channel" led to a certain increase in the efficiency of trapping fine particles, but at the same time the hydrodynamic resistance of the entire system increased substantially, which required the presence of additional devices for increasing the pressure of the dusty air [7,11].

The air purification device was also proposed earlier, containing discharge chambers in the form of shaped cylinders with the mesh bottom and with the placement of corona electrodes made in the form of needles on grids that were arranged in series in a vertical direction and alternately were connected to different poles of the power source [12]. However, the drawback was the complexity of the design, which made it difficult for polluted air to pass.

The authors propose a new solution to this problem. The new discharge device for air purification is provided with negatively charged electrete plates installed alternately and corona electrodes in the form of needles on the grid that are located along the direction of the flow of dusty gas. In the device, the processes of charging aerosol particles are carried out in the zone of the positive corona, which allows to reduce by times the efficiency of ozone formation in the purified air in comparison with the negative corona. The device uses a (multi-electrode) micro-electrode system of corona needles, which dramatically increases the effect of electric wind, which is an obligatory attribute of the corona discharge. Electric wind creates a high-speed head of air flow (up to 5 m/s) in the working area and makes the device operate in the mode of ion-convection pump.

The processes of deposition and collection of aerosol particles occur in the zone of alternately arranged electrete plates at the outlet of the device. In view of the fact that electrete plates are negatively charged and the processes of deposition of positively charged aerosol particles on them proceed most efficiently.

Figure 1 shows the functional scheme of the proposed device in a section. It comprises a housing of a dielectric material of rectangular shape 1, corona needles 2, the outer electrode in the form of metal mesh 3 and the electrete plates 4 arranged alternately in the second part of the housing 1a. Coronating needles 2 in the number of 5 or 9 pieces are fixed symmetrically and coaxially to the housing 1, to the metal grid. In the operating mode, a high positive voltage is applied to the corona electrodes from the power supply (unit) block (БП) via the Пв switch of position I. In position II of switch П, the electrete plates are charged in the negative corona zone. For the convenience of cleaning the electrete plates from the aerosol particles

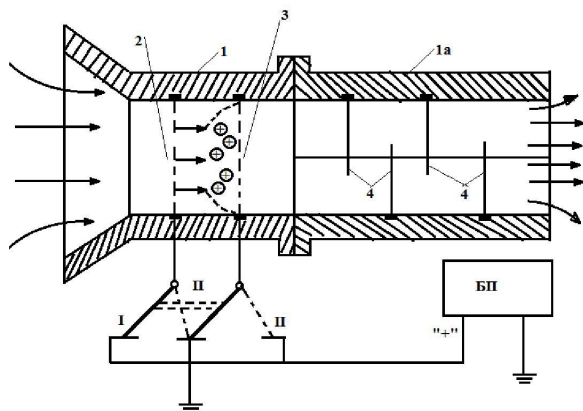

Figure 1 – Functional scheme of the device

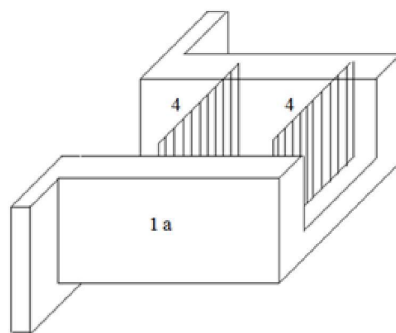

Figure 2 – Scheme of the location of electret plates

collected on them, the second part of the housing 1a is made of two halves, identical in shape and size and only with the difference in the location of the electret plates on them (Figure 2).

Electret plates are made of a dielectric, for example, PTFE (polytetrafluor(o)ineethylene), which for a long time (up to 10 days) retains the electrified state after the end of the external action that caused electrification. One of the methods of electrifying electretes is the impact on them by the corona discharge. In the proposed device, with the II position of the switch II, electrification conditions of the electret plates of negative polarity are provided. This possibility allows the electrification process to be combined with the air purification process, moreover, neutralization of the charged electret plates under the influence of positively charged aerosol particles proceeds intensively.

In the manufacture of the electret plates, on the plates of dielectric with a thickness of 2 mm, an electret film of PTFE with a thickness of 100 micrometers is glued, while the strength of the breakdown field E_{mp} is up to $2.2 \cdot 10^3$ kV/cm, and the surface density σ_s is 0.4 and 0.24 C/cm² [14].

After supplying a sufficiently high voltage to the electrodes in the form of needles 2, the corona discharge occurs between them and the wire electrode 3, simultaneously, the electric wind is generated in the direction of the corona needles 2, with a time (not more than 5 s) in the discharge zone, a stable electric wind appears and the device starts to work in the mode of ion-convection pump.

In this connection, the processes of sucking dusty air into the device and charging aerosol particles in the discharge zone begin. Then, the positively charged aerosol particles enter the next zone, where they are subjected to additional acceleration by the electric field created by the negatively charged electret plates. Further passing through the labyrinth of the electret plates, the aerosol particles settle on them and at the output we obtain pure air. In the case of heavily dusty air, the number of electret plates can be increased, but the limiting value of the hydrodynamic resistance of the entire system must be taken into account.

The device was tested with the following parameters: the radius of the needles is 0.2 mm, the housing made of dielectric material of rectangular shape has internal dimensions of 15x20 mm², the grid window is 2x2 mm², the distance between the needles and the grid electrode is 8 mm, the supply voltage can vary from 6 to 14 kV, the working current of the corona discharge can be chosen in the range from 10 to 20 μ A, depending on the degree of dustiness of atmospheric air. The device consisting of a single corona needle and one electret plate was tested in smokiness of atmosphere.

Control tests showed that the device is suitable for air purification from finely dispersed aerosol particles and can be used in production and service premises of poultry farming. With this simplified version of the device, after some time (no more than 5 s), the stable electric wind appears and the aerosol particles are drawn into the device. With increasing air contamination, approximately 2 times, the operating current is reduced by 6 μ A, which shows a significant dependence of the corona current on the degree of contamination of atmospheric air.

It is established that a decrease in the air pressure in the discharge gap leads to the increase in the ozone yield at low energy costs.

Innovative and competitive advantage is the possibility of obtaining the same amount of ozone in small-sized devices for processing food products, the advantage of which in comparison with foreign analogues is the small dimensions of the corona electrodes, the diameter of which does not exceed 100 microns, that allows to significantly reduce the capital costs of the installation for processing agricultural products, the cost of the production line will be lower by 5-10 times compared to analogues [11].

REFERENCES

- [1] Ospanov E.S., Kaygorodtsev. A.A. Food security of Kazakhstan: theory and practice. Messenger KACY, 2006. N 4. P. 11.
- [2] Zambecova Z.H. Food security of Kazakhstan: theoretical aspects and hrioietyobespechenija: abstract of candidate of economic sciences. Karaganda, 2008. 21 p.
- [3] Tatimov M.B. That waits for Kazakhstan in the overpopulated XXI century. Metropolitan display. Almaty, 1999. N 1-2. P. 5-6.
- [4] Donchenko L.V., Nadukta V.D. Food Security Pishhepromizdat, 2001. 528 p.
- [5] Belenky N.G. Issue biological assessment of raw materials and food products. M., 1976. 86 p.
- [6] Belenky N.G. Biological value of products of animal origin as a basis for choosing rational technology for their production. //In the book Improving the quality of livestock products. M., 1978. P. 10-39.
- [7] Authorship certificate USSR №325996. Device for assessing // Bahtaev Sh.A. Publ. Bull. №3, 16.03.1972.
- [8] Reference book for electrical engineering in the 3 volume. L.: Energiatompublishing, 1988. Vol. 3. P. 591-605.
- [9] Sydykova G.K. Study and development of small-sized ozonizers and ozone control methods based on the Crown: Candidate of technical sciences: Avtoreferag. Almaty, 2001. 17 p.
- [10] Lunin V.V., Popovich M.P., Tkachenko S.N. Physical chemistry of ozone. M.: MGU, 1998. 480 p. 11. Bahtaev Sh.A.: Diss. dokt. of science. Almaty, 2004. 330 p.
- [11] Authorship certificate KR №20892. Device for assessing // Bahtaev Sh.A., Bokanova A.A., Mataev U.M., Abdurakhmanov A.A. Publ. Bull. №3, 16.03.2009.
- [12] Mataev U.M., Abdurakhmanov A.A. Establishment of mathematical model for the measurement of electrical characteristics of ozone generator // Proceedings of the international scientific and practical Conference "Standartization, Metrology and certification: integration into international space". Astana, 2011. P. 149-153.
- [13] RK innovative patent. Device for assessing for ai // Bahtaev Sh.A., Bokanova A.A., Mataev U.M., Abdurakhmanov A.A. Publ. Bull. №3, 16.03.2009.

А. А. Абдурахманов, Ш. А. Бахтаев, Ә. Ә. Боқанова, У. Матаев

Алматы энергетика және байланыс университеті, Қазақстан

ҮЙДЕГІ АУАНЫҢ ҚҰС ФАБРИКАСЫ ҚҰРЫЛҒЫНЫ ТАЗАЛАУҒА АРНАЛҒАН

Аннотация. Өндіру және қайта өңдеу (озон) үшін тиімді, энергия үнемдейтін технологияларды және инновациялық техникалық құралдарды әзірлеу құс, құс еті мен жұмыртқа, және олардың табыстылығын және бәсекеге қабілеттілігін арттыру мақсатында құс фабрикаларын өз енгізумен үй-жайлар. Осы орайда, бұл теріс кезекпен қаланды электретный табақшаларды және бағыттаушы шанды газ ағынымен бірге ұйымдас-тырылған тор бойынша инелер түрінде разряд электродтары зарядталған жабдықталған ауаны тазарту үшін инновациялық құрылғыны ұсынды.

Түйін сөздер: тәжді разряд, электрет паракшалар, озонатор, электрод, тор.

А. А. Абдурахманов, Ш. А. Бахтаев, А. А. Боқанова, У. Матаев

Алматынський университет энергетика и связи, Казахстан

УСТРОЙСТВО ДЛЯ ОЧИСТКИ ВОЗДУХА ПОМЕЩЕНИЙ ПТИЦЕФАБРИК

Аннотация. Разработка эффективной, энергосберегающей технологии и инновационных технических средств для генерации и обработки (озоном) помещения с содержанием птиц, мяса птицы и яиц и внедрение его в птицефабриках с целью повышения их рентабельности и конкурентоспособности. В связи с этим предлагается инновационное устройство для очистки воздуха, снабженное отрицательно заряженными электретными пластинами, установленными поочередно и коронирующими электродами в виде игл на сетке, которые расположены по направляющей потока запылённого газа.

Ключевые слова: коронный разряд, электретные пластины, озонатор, электрод, сетка.

Абдурахманов Абдугани Абдужалилович – старший преподаватель

Бахтаев Шабден Абуович – д.т.н., профессор

Боқанова Алия Абылгазиевна – д.т.н., профессор

Матаев Умербек Матаевич – к.т.н., доцент.